



*Official 2024 (for 2025)  
Miss Rodeo Kentucky Pageant  
Rules and Regulations*

**Miss Rodeo Kentucky, Inc.  
President, National Director:**  
Megan Devine-Coady  
[megandevinecoady@gmail.com](mailto:megandevinecoady@gmail.com)  
(516) 721-6376

**Miss Rodeo Kentucky, Inc.  
Pageant Director:**  
Lauren Johnson  
[missrodeokentucky@gmail.com](mailto:missrodeokentucky@gmail.com)  
(812) 498-8592

Copyright © 2024 Miss Rodeo Kentucky, Inc.

**ALL RIGHTS RESERVED**

MRKy reserves the right to modify or revise these rules at any time upon reasonable notice.

## Miss Rodeo Kentucky, Inc. Information

**Mission:** Miss Rodeo Kentucky, Inc. is a state-level organization under Miss Rodeo America, Inc. The mission of the organization is to select one young woman in each division to serve as an official ambassador who will promote the Professional Rodeo Cowboys Association (PRCA), our Agricultural Industry, the Western way of life, and the Commonwealth of Kentucky at the annual Miss Rodeo America pageant. Our primary goal is to provide educational and career-building opportunities to the young women who compete in the pageant and to foster their growth and development to be professional leaders of tomorrow.

### Who are the Miss Rodeo Kentucky titleholders?

Miss Rodeo Kentucky titleholders symbolize the youth of our state who wish further to promote Professional Rodeo, Agriculture, and Western traditions. She is a quintessential, American girl who embodies the qualities of integrity, impeccable character, and class while traveling across the Commonwealth of Kentucky and the length of this great nation.

### Miss Rodeo Kentucky Contestant Characteristics:

- Intelligence
- Ability to converse about trending topics in rodeo, agriculture, and the Western industry
- Ambassador for the Western way of life
- Community leader
- Experienced horsewoman
- Excellent sportsmanship
- Animal welfare advocate
- Congenial, able to converse with rodeo fans from all walks of life
- Sincere interest in the future of rodeo and agriculture
- Insatiable work ethic

# Miss Rodeo Kentucky Pageant Requirements

- **Pageant Deadlines:**
  - **September 30, 2024:**
    - \$150 entry fee (paid at the time of application submission)
    - \$300 minimum in program ad sales (All ad submissions, including artwork, must be received by this deadline to ensure meeting the print deadline)
  - **November 14, 2024 at Contestant Check-In:**
    - Sell a minimum of 10 MRK Pageant Tickets
  - If there are any questions about deadlines or fees, please get in touch with the Pageant Director.
- As required by the MRKy Contestant Application, each completed application should include entry blank, proof of birth (copy of birth certificate or baptismal certificate), proof of residency (copy of driver's license, high school, and/or collegiate transcript), horsemanship release, participant release, size chart, photo copyright release, and a digital copy of an 8x10 headshot in a .jpeg or .png format. All components must be included in the entry form by the entry deadline.
- All components listed above are required portions of the Miss Rodeo Kentucky/Miss Teen Rodeo Kentucky/Junior Miss Rodeo Kentucky Contestant Application. All Contestant Applications and other required information must be received by the above deadlines or the contestant will be ineligible to compete in the Miss Rodeo Kentucky Pageant. Upon receipt of the entry application and minimum ad sales requirement, the applicant will then receive all pertinent information regarding the state pageant competition.
- Contestants in the MRKy Pageant are required to pay their own transportation to and from the Pageant, which will be held in Louisville, KY. All food and lodging during the MRKy Pageant will be paid by the Miss Rodeo Kentucky Pageant. Junior Miss contestants are permitted to stay with their parents for the duration of the pageant.
- All horses and tack will be provided during the horsemanship competition and rodeo performances, for Miss and Teen contestants. Junior Miss contestants will be required to submit their horsemanship pattern via a live Zoom conference before the beginning of the pageant.
- Contestants currently carrying a title are NOT permitted to wear their local title crowns or banners during the Miss Rodeo Kentucky Pageant if they have one.
- Contestants will be given a contestant banner to wear for the duration of the pageant. The banner is to be turned back in during the coronation on the last day of the pageant. MRKI will supply the banners, however no crowns will be permitted.
- Except for the Junior Miss division, contestants will be under the supervision of the Miss Rodeo Kentucky Chaperones from the time of the official contestant check-in until they are signed out by Pageant Officials after the completion of the pageant, by the contestant herself or by one of her parents. Contestants under the age of 18 MUST be signed out by a parent. The chaperones will escort the contestants to and from all functions during MRKy

Pageant weekend. A contestants' hospitality room will be available to receive all congratulatory letters and emails, phone calls, flowers, dry cleaning, etc. A contestants' suite will be available for their meetings and interviews.

- Parents, relatives, and supporters of MRKP Contestants are welcome to attend certain pageant events that will be open to the public; however, after official contestant check-in, contestants are not permitted to communicate with family or friends unless authorized by Pageant Officials.
- All transportation needs for contestant functions outside of the hotel will be provided.
- Two representatives from the parents' group will be selected to act as a parents' judging/grievance committee. In the event of an unresolved dispute, the MRKY Executive Board will make the final decision.
- Recording/Photography Equipment – video or recording equipment and photography equipment of any kind, including personal electronic devices, will not be allowed at pageant functions. Unauthorized equipment is subject to temporary confiscation.
- Judging will take precedence over all pageant activities. It will begin at contestant check-in and continue throughout the pageant.

# Miss Rodeo Kentucky Pageant

## Miss (20-25 years old) Division Contestant Eligibility:

Each contestant in the Miss Rodeo Kentucky Division shall:

1. be a naturally born female and identify as female,
2. will be 21 years of age by November 1, 2025 and will be no older than 26 years of age as of December 31, 2025.
3. have obtained a high school diploma or equivalent of high school education, and are able to remit proof of enrollment upon request,
4. not be, nor ever have been, previously or currently married and/or pregnant,
5. be a permanent resident of Kentucky, or have been attending a recognized college/university in the Commonwealth for a minimum of two (2) consecutive semesters,
6. not have been a previous Miss Rodeo Kentucky or other MRA State titleholder and/or competed in a Miss Rodeo America Pageant,
7. not be a **current** state or national titleholder of any other organization (i.e., Miss Kentucky High School Rodeo Association, Miss National Little Britches Rodeo Association, Miss Rodeo USA, etc.),
8. have executed all consents and/or waivers of liability presented as conditions precedent to competition,
9. abide by all rules and regulations set forth by the Miss Rodeo Kentucky Pageant,
10. no title can be held concurrently with the Miss Rodeo Kentucky title. All other titles must be passed down/forfeited at the time of officially taking the Miss Rodeo Kentucky crown, if applicable.

## Teen (15-19 years old) Division Contestant Eligibility:

Each contestant in the Miss TEEN Rodeo Kentucky Division shall:

1. be a naturally born female and identify as female,
2. not be less than 15 years of age, nor will I be more than 19 years of age, on the date of the beginning of the State Pageant.
3. shall be enrolled in or have graduated high school and/or college, completed the equivalent of high school education, and be able to remit proof of enrollment upon request,
4. not be, nor ever have been, previously or currently married and/or pregnant,
5. be a permanent resident of Kentucky, or have been attending a recognized college/university in the Commonwealth,
6. not have been a previous Miss Teen Rodeo Kentucky,
7. not be a **current** state or national titleholder of any other organization (i.e., Miss Kentucky High School Rodeo Association, Miss National Little Britches Rodeo Association, Miss Rodeo USA, etc.),
8. have executed all consents and/or waivers of liability presented as conditions precedent to competition,
9. abide by all rules and regulations set forth by the Miss Rodeo Kentucky Pageant,
10. no title can be held concurrently with the Miss Teen Rodeo Kentucky title. All other titles must be passed down/forfeited at the time of officially taking the Miss Teen Rodeo Kentucky crown, if applicable.

## **Junior Miss (10-14) Division Contestant Eligibility:**

Each contestant in the JUNIOR MISS Rodeo Kentucky Division shall:

1. Be a naturally born female and identify as female,
2. Will not be less than 10 years of age, nor will I be more than 14 years of age, on the date of the beginning of the State Pageant.
3. shall be enrolled in school and be able to remit documentation upon request,
4. not be, nor ever have been, previously or currently married and/or pregnant,
5. be a permanent resident of Kentucky,
6. not have been a previous Junior Miss Rodeo Kentucky,
7. not be a **current** state or national titleholder of any other organization (i.e., Miss Kentucky High School Rodeo Association, Miss National Little Britches Rodeo Association, Miss Rodeo USA, etc.),
8. have executed all consents and/or waivers of liability presented as conditions precedent to competition,
9. abide by all rules and regulations set forth by the Miss Rodeo Kentucky Pageant,
10. no title can be held concurrently with the Junior Miss Rodeo Kentucky title. All other titles must be passed down/forfeited at the time of officially taking the Junior Miss Rodeo Kentucky crown, if applicable.

Any contestant not meeting the above requirements will be denied entry to compete in the Miss Rodeo Kentucky Pageant.

## **Loss of Title and Benefits:**

Subsequent to the Miss Rodeo Kentucky Pageant, any person being awarded the title of Miss Rodeo Kentucky, Miss Teen Rodeo Kentucky, Junior Miss Rodeo Kentucky and/or otherwise becoming the successor thereto, shall not;

1. currently be or have been previously married and/or pregnant,
2. be charged with and/or determined to have committed any crime of moral turpitude,
3. compete in and/or otherwise participate in any other beauty and/or talent contest, pageant and/or activity,
4. solicit, negotiate or contract with any third party for appearance photographs, interviews, sponsorships, and/or endorsements during the year of her reign. Upon the occurrence of any of the above events, the title of Miss Rodeo Kentucky/Miss Teen Rodeo Kentucky/Junior Miss Rodeo Kentucky together with any benefits derived by such person, shall be forfeited and awarded to the next qualified runner-up,
5. have taken any actions, which in the good faith determination of the Executive Board of MRKI, will or is reasonably likely to cause harm or damage to the goodwill of reputation of MRKy.
6. violate any provisions of the Pageant Rules and Regulations or Miss Rodeo Kentucky/Miss Teen Rodeo Kentucky/Junior Miss Rodeo Kentucky Contract and/or Rules Statement/Consequence Matrix.

## Pageant Categories

**Horsemanship-** the purpose of this division is to select a young lady who rates the highest in:

- Horsemanship – the include control of mount and the way any situation which may occur is handled.
- Balance – ability to sit a saddle.
- Positions of hands, feet and seat.
- Mounting and Dismounting.

The understanding and skill of the contestant will be judged and not the horse and/or equipment. Splits reins will be required and provided (for Miss and Teen contestants only). There will be two rounds of horsemanship competition. The first round, a set horsemanship pattern, can be found in this rulebook.

For the second round, the contestants will be required to complete a freestyle pattern within 1.5 minutes to include, but not be limited to, the following four elements:

1. Presentation run
2. Lead change
3. Stop
4. Back

These elements do not have to be completed in the order they are written in this rulebook. Time will start when the shoulder of the horse crosses the plane of the gate. There will be a warning given with 30 seconds remaining. Time will stop when the announcer says, "Time is up." Once time is called, the contestant must stop where they are and exit the arena.

At the discretion of the Judges, patterns may be altered due to arena and/or weather conditions. Contestants may also be required to dismount/remount, carry a flag and perform additional maneuvers on horseback. Contestants may or may not be asked to do a presentation run following the completion of their pattern. Any changes and/or alterations to the horsemanship patterns will be announced to the contestants before the horsemanship competition begins. The pattern will be demonstrated by the reigning Miss Rodeo, Miss Teen, and Junior Miss.

Dress for horsemanship, is a **WRANGLER** brand pant product; formfitting blouse or shirt with long-sleeves (any color) with shirt tail tucked in, western boots. No vests, no jackets. Any color accessories (hat, boots, belt) may be used. Gloves are optional, chaps and spurs are not allowed in the State Pageant. All riding attire should be neat and fit properly. Showmanship should be considered, since a contestant's personality does project from horseback to the audience and judges.

Each contestant will ride a horse in each of two go-rounds of horsemanship competition. As in rodeo, there will be a draw for the order in which contestants compete, and a draw for each contestant's mount. No contestant will ride the same horse in both go-rounds. **All horses and tack will be provided during the horsemanship competition and rodeo performances, for Miss and Teen contestants. Junior Miss contestants will be required to submit their horsemanship pattern via a live Zoom conference before the beginning of the pageant.**

Contestants will ride the patterns selected for their division as determined in the MRKy Pageant Rulebook. **Each of the three divisions will have its own designated pattern.** The MRKy Pageant Judges reserve the right to make alterations and/or additions to these instructions. Patterns have been selected from the many provided by the American Quarter Horse Association (AQHA).

## Junior Miss Division Pattern

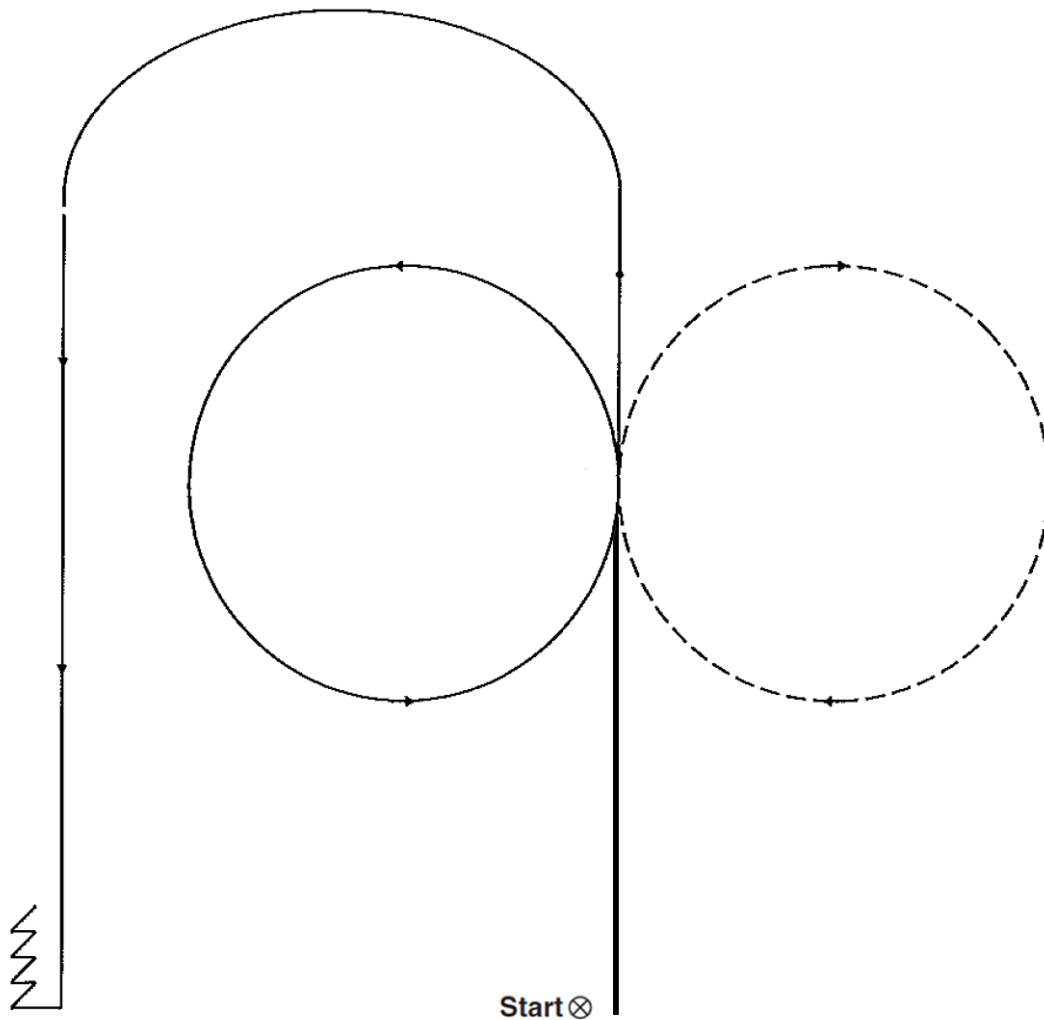

Ride as follows:

1. Jog to center and execute a circle to the right.
2. Upon completion of the circle, pick up the left lead and lope a circle to the left.
3. After completing the circle, lope straight and around the end of the arena, and down the long side.
4. Stop and back 4 steps and wait for judges' instructions/dismissal.



## Teen Division Pattern

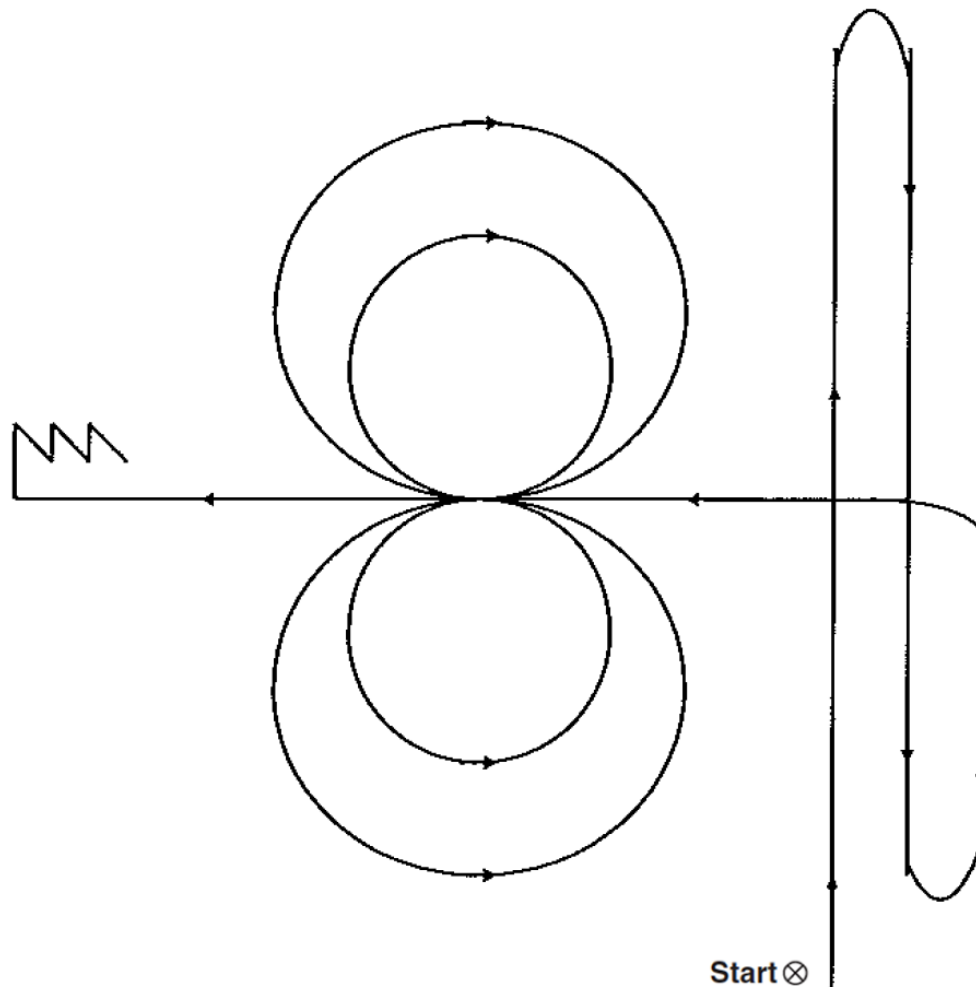

Ride as follows:

1. Begin on the right side of the arena and lope to the far end of the arena.
2. Stop and rollback to the right before continuing to the other end of the arena.
3. Stop and rollback to the left before continuing to the other end of the arena.
4. Lope a small, slow circle to the left, and then lope a large, fast circle to the left.
5. Change leads.
6. Lope a small, slow circle to the right, and then lope a large, fast circle to the right.
7. Upon completing the circle lope straight to the fence and stop.
8. Back one horse length and wait for judges' instructions/dismissal.

## Miss Division Pattern

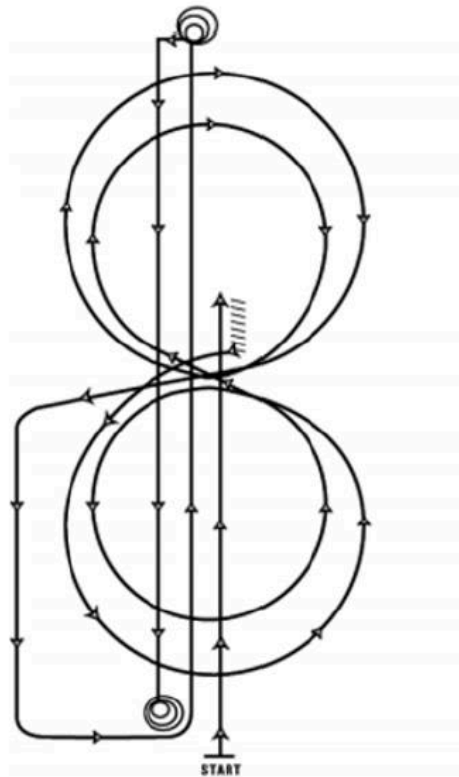

Ride as follows:

1. Start at end of arena.
2. Run past the center marker and stop.
3. Back up at least 10 feet.
4. Complete 1/4 turn to the left.
5. Complete 2 circles to the left, the first one large and fast and the second small and slow. Change leads at the center of the arena.
6. Complete two circles to the right, the first on small and slow, the second large and fast. Change leads at the center of the arena.
7. Continue around end of arena without breaking gait or changing leads, run down center of arena past end marker, come to a square sliding stop.
8. Complete 3 1/2 spins to the right.
9. Run down center of arena past end marker and come to a square sliding stop.
10. Complete 3 1/2 spins to the left.
11. Wait for judges' instructions/dismissal.

## Knowledge & Presentation

The purpose of this division is to select a young lady who rates the highest in:

Knowledge – well studied and understands the areas of rodeo, equine, animal welfare, topics related to agriculture, and current events. Information contestants should be familiar with include, but are not limited to, the following:

- PRCA, WPRA Current News/Events
- PRCA/WPRA Rules
- PRCA/WPRA Media Guides
- AQHA Information
- Equine Anatomy/Physiology
- Equine Science
- Equine tack
- Politics
- U.S. News
- World News

Presentation – ability to handle all competition situations with poise and maturity. Preparedness for events/appearances/etc.; self-control and confidence while speaking in public or interacting with others; exhibiting grace and class while being flexible in and out of the public eye. There is no “off-time” when holding a rodeo queen title and your demeanor should reflect as such.

\*Do consider - not only will your knowledge be judged through your answers to the material on the written exam, but also in the content, quality, and delivery of your answers in both interviews and on-stage questions.

## Personality

The purpose of this division is to select the young lady who rates the highest in:

- Intelligence – good and mature common sense when answering difficult questions, and ability to “think on her feet”.
- Education – conversational ability in rodeo, agriculture, and today’s society, with emphasis on grammar and enunciation.
- Self–projection – to include contestant style of attire, overall appearance, etc.; also, the ability to project one’s personality to an audience, whether that is on stage, on horseback in an arena, or on television.
- Genuine interest in other people and a noticeable consideration of others.
- Promptness in keeping to pageant schedule. Judges will be informed if a contestant is late at any point during the pageant.

## Appearance

The purpose of this category is to select the young lady who rates the highest in:

- Attractiveness
- Grooming – to include neatness and cleanliness in every detail, such as complexion, hands, fingernails, hat, boots, and other apparel. Meticulous care in grooming is essential for a young lady to be considered for the title of Miss Rodeo Kentucky.
- Photogenic Quality – A young lady’s personality and wholesome values are strongly projected in appearance through photography.
- Poise – Professional and classy behavior is required in all situations.
- Knowledge of Proper Western Attire – contestants should be aware of fashionable western attire, with particular attention given to color coordination, and colors can enhance their own appearance. Judges will be considering how a contestant’s clothing fits and suits personality to that particular individual. **Contestants are expected to be in full western attire at all times, unless specified.** All outfits should include western hat, boots, belt, buckle, and contestant banner (banner will be provided), unless otherwise specified.
- **It is mandatory that contestants wear a WRANGLER brand product whenever they are in pants.**
- There are no collar height requirements for the Miss Rodeo Kentucky Pageant.
- Per PRCA Dress Code, all arena/horsemanship tops must have a full-length sleeve.
- All dresses must have sleeves no shorter than a cap sleeve. A jacket must be worn if a top or dress does not have sleeves. Skirt length should be no more than three inches above the knee. No halter or prom type dresses will be permitted. No midriff, low-cut garments. The goal is to project a wholesome, western image. If you wear a pant product it MUST be Wrangler.
- It is not necessary to invest in an excessive amount of expensive clothing. Judges will be looking for personality expressed through clothing, not price tags.
- Contestants should be knowledgeable on current western fashion trends and Miss Rodeo Kentucky Pageant, as well as Miss Rodeo America, apparel sponsors.

# Pageant Judging Guidelines

Miss Rodeo Kentucky/Miss Teen Rodeo Kentucky/Junior Miss Rodeo Kentucky contestants are judged in four categories, all of which are equal: Horsemanship, Personality, Appearance, and Knowledge & Presentation. In addition, the scores from contestant's public speaking, photogenic photo, interviews, speech, introductions, fashion show presentation, written test, etc. will be factored into those categories.

**If there is only one contestant in a division, that contestant must earn at MINIMUM 75% of the overall points to be awarded the title.**

## Judges

1. A minimum of three judges will judge ALL portions of the Pageant. Scores will be totaled once judging is complete. The Miss Rodeo Kentucky Board of Directors reserves the right to have a lesser number of judges in the event of extenuating circumstances.
2. Judges are selected for their expertise in all fields of the competition; horsemanship, personality, appearance, knowledge and presentation, etc. They should have a working knowledge of current trends in the western fashion industry, be knowledgeable and up-to-date on current events in the worlds of professional rodeo and agriculture.
3. All decisions of the judges are final.
4. MRKy will implement appropriate standards to ensure that all judges are impartial and have an appropriate level of knowledge and experience in all categories.
5. MRKy Executive Board will have the final say in the selection of MRKy Pageant Judges.
6. In the event of any dispute concerning the decision of the judges, such dispute will be settled by the MRKy Executive Board. The review shall be limited to determining whether judges were acting in good faith and impartially. If it is found they were not in the discretion of the Executive Board, such judge will be removed from the panel immediately. All decisions of the Executive Board are final.

## Judged Events

1. **Horsemanship** – Each contestant will ride a horse in each of two go-rounds of horsemanship competition. As in rodeo, there will be a draw for the mount ridden and the order in which contestants compete. All horses and tack will be provided. Contestants will not ride the same horse in both go-rounds of horsemanship competition.
2. **Public Speaking** –
  - a. **Extemporaneous Speech** –
    - i. Each MISS and TEEN contestant will receive a list of topics from Pageant Officials. There will be 10 minutes for each contestant to prepare a speech around one of the topics provided. Judging is based upon content, delivery, the ability of the contestant to “think on her feet” and the time allotted for the presentation. Miss and Teen contestants will have 1.5 minutes to deliver their speech.
    - ii. JUNIOR MISS contestants will give a 1 minute prepared speech about their state and/or the sport of rodeo.
  - b. **Media Interview** – The media event will be recorded live after Orientation. It will be done in a “sports broadcast” style (i.e. Kadee Coffman interviewing contestants at the WNFR). Judging is based on knowledge, ability to think quickly, and delivery. The contestant with the highest total score in the speech/media interview category will be recognized as the speech award winner.
1. **Interviews** – Each contestant will be interviewed privately by the judges. Questions asked will pertain to the contestant’s knowledge of the pageant, professional rodeo, horsemanship, and worldwide current events. Each contestant may be interviewed on each of the following categories; knowledge of tack, equine care, diseases and medication, anatomy, etc.; knowledge of professional rodeo, its history, organization, rodeo terminology, PRCA and WPRA current events, PRCA and WPRA world standings, etc.
  - c. Excellent sources of information include the ProRodeo Sports News, published twice monthly by the PRCA; the official PRCA Rule Book, and the Official ProRodeo Media Guide, all of which are available from the PRCA, 101 Pro Rodeo Drive, Colorado Springs, CO, 80919 or on [www.prorodeo.com](http://www.prorodeo.com).
  - d. Additional information can be found at [www.prorodeo.com](http://www.prorodeo.com) or [www.wpra.com](http://www.wpra.com). Information on agriculture in your state or nationally can be researched via the internet.
2. **Extemporaneous Questions** – Extemporaneous questions will be asked of each contestant during pageant functions. Questions may relate to the sport of professional rodeo, agriculture, personality/opinion, and/or current events.
3. **Modeling** – Contestants will participate in at least one fashion show.
4. **Photogenics** – Using photos shot by the official pageant photographer, judges will be looking for personality, attractiveness, and camera appeal in their scoring.

## Category Winners

The category winners – horsemanship, personality, appearance, speech and written test – will be determined by the total scores in those respective categories.

- **Appearance** – The winner of the Appearance category will have the highest cumulative total of appearance scores received in all judged events.
- **Personality** – The winner of the Personality category will have the cumulative total of personality scores received in all judged events.
- **Horsemanship** – The winner of the Horsemanship category will have the highest cumulative total of horsemanship scores received in the two horsemanship go-rounds, horsemanship interview, and their Rodeo/Horsemanship impromptu question.
- **Knowledge & Presentation** – Points earned in this category will be applied to scores in other divisions based upon which judged event where earned.
- **Written Test**- The winner of the Written Test category will have the highest total score from the written test that all contestants will take.

## Other Awards

The following awards will be given during coronation, but DO NOT count towards a contestant's overall score.

- **Miss Congeniality** – This award is voted on by the Miss Rodeo Kentucky Pageant contestants. If there are more than two contestants in each division, a “Miss Congeniality” will be awarded for each. If there are 2 or less in a pageant division, “Miss Congeniality” will be awarded to only one contestant across all three divisions.
- **Miss Photogenic** - This award is voted on by the Miss Rodeo Kentucky Pageant judges. If there are at minimum three contestants in each division, a “Miss Photogenic” will be awarded for each. If there are 2 or less in a pageant division, “Miss Photogenic” will be awarded to only one contestant across all three divisions.
- **Rising Star Award** – This award will be given to a young lady who shows ambition and a history of success in and out of the rodeo arena. This award is voted on by the Miss Rodeo Kentucky Pageant Judges.
- **Community Spirit Award** – The winner of this award will show responsibility, ambition and a willingness to assist others. This award is voted on by the Miss Rodeo Kentucky, Inc. Pageant Committee.
- **High Sales Award** – The contestant who sells the highest dollar amount of pageant tickets and program ads combined will receive this award.
- **Peoples' Choice** – The contestants with the highest number of votes from the online voting will receive this award.

*All prizes awarded to Miss Rodeo Kentucky, Miss Teen Rodeo Kentucky, Junior Miss Rodeo Kentucky and/or State Pageant participant, are subject to change without notice. Additionally, any prizes awarded by any third party may be subject to additional eligibility requirements beyond those set forth in these rules.*

## Scoring Criteria

Points will be awarded to contestants in the major categories of Personality, Appearance, Horsemanship, and Knowledge & Presentation (All are 300 points per category).

The contestant receiving the highest score in each age division for the week shall be named Miss Rodeo Kentucky/Miss Teen Rodeo Kentucky/Junior Miss Rodeo Kentucky. That contestant receiving the second highest grand total shall be first runner-up. That contestant receiving the third highest grand total will be the second runner-up, etc.

Ties for category winners, i.e., Appearance, Personality, Horsemanship, will be broken by referring back to Judge #1. Judge #1's score will break the tie. If a tie still remains, Judges #2's score will be used... and so on until the tie is broken.

Ties resulting in Photogenics and Speech will be broken by using the same method as the other category winners.

A tie for Miss Congeniality will be broken by a second balloting by contestants.

A tie for Miss Rodeo Kentucky/Miss Teen Rodeo Kentucky/Junior Miss Rodeo Kentucky or runners-up will be broken by the horsemanship riding score, i.e., the contestant with the best equitation will receive the higher ranking.

A tie for the written test will be broken by the horsemanship interview score.

Judges' comments will be emailed to contestants following the conclusion of the pageant.



# Pageant Organization Formal Complaint/Grievance Process

**Any complaint that is filed regarding Miss Rodeo Kentucky Pageant and/or Miss Rodeo Kentucky, Inc. operations must adhere to the following:**

1. All complaints must be submitted in writing, PDF format within 48 hours from the completion of the pageant and/or incident.
2. Complaints must include the name, address, and daytime phone number of the person filing the complaint.
3. The complaint should include as much detail about the subject as possible for appropriate action to be taken.
4. Complaints may be submitted to the following:  
Miss Rodeo Kentucky, Inc.  
c/o Megan Devine-Coady  
298 Veech Road  
Fisherville, Kentucky 40023
5. Complaints must be signed and dated.
6. If a response is required, the letter must indicate so.
7. Any complaints that do not follow the above process will be classified as invalid.

## **MRKI Office follow-up procedure:**

1. All grievances will be reviewed by the Miss Rodeo Kentucky, Inc. Board of Directors.
2. A MRKI Board of Director member will be assigned to research and gather information about the grievance.
3. All parties involved will be notified about the grievance in writing and given the opportunity to provide a response in writing.
4. The findings will be reported back to the MRKI Board of Directors.
5. The MRKI Board of Directors will vote and determine necessary action to be taken.
6. A MRKI Board of Director representative will report back to all parties.
7. A decision will be sent to all parties, signed, and dated by the MRKI Board of Director assigned to the grievance.
8. All grievances will be addressed and responded to by the MRKI Board of Directors within 10 business days of the initial date the grievance was received.
9. The MRKI Board of Directors has the right to extend the 10-day period if further examination is necessary. They will advise all parties in writing if this is necessary.

## Additional Resources

### **Miss Rodeo Kentucky, Inc.**

Information at [www.missrodeokentucky.com](http://www.missrodeokentucky.com)

Facebook: Miss Rodeo Kentucky, Inc.

Instagram: @missrodeokentucky

TikTok: @missrodeokentucky

### **Miss Rodeo America, Inc.**

Information at [www.missrodeoamerica.com](http://www.missrodeoamerica.com) or [www.facebook.com/missrodeoamerica](https://www.facebook.com/missrodeoamerica)

### **Professional Rodeo Cowboys Association (PRCA)**

Information at [www.prorodeo.com](http://www.prorodeo.com)

PRCA Business Information [www.prorodeo.org](http://www.prorodeo.org)

### **Women's Professional Rodeo Association (WPRA)**

Information at [www.wpra.com](http://www.wpra.com)

### **American Quarter Horse Association (AQHA)**

Information at [www.aqha.com](http://www.aqha.com)